

PROPRIETARY INFORMATION
COMPANY CONFIDENTIAL

| REV. | ECN. NO. | DESCRIPTION | ENG | DATE |
|------|----------|---------------------------|-------|------------|
| X1 | | INITIAL | AXL | 1/28/2021 |
| X2 | | UPDATE DRAWING | JOE | 2/20/2021 |
| X3 | | UPDATE NOTE | Joy | 9/10/2021 |
| X4 | | CHANGE SHELL PLATING SPEC | TERRY | 11/10/2022 |

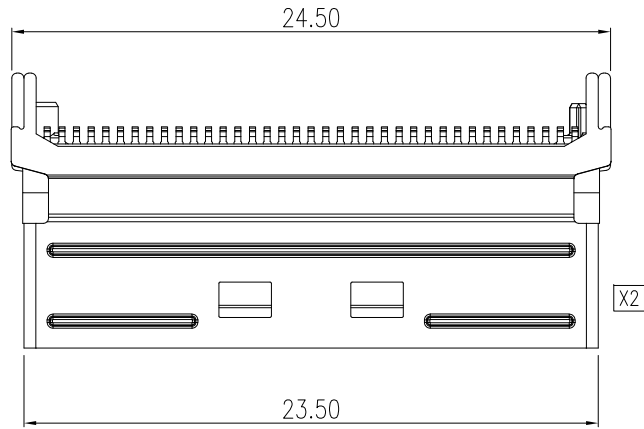

NOTES:
MATERIAL:

- 1: HOUSING: SOLDER REFLOW PROCESS COMPATIBLE LCP, UL94V-0
- CONTACTS: HIGH PERFORMANCE COPPER ALLOY
- X4 SHELL: SUS, NICKEL PLATED OVERALL
- 2: ROHS COMPLIANT
- 3: GEN5 COMPLIANT
- 4: FITS LOW PROFILE PLUG ONLY.

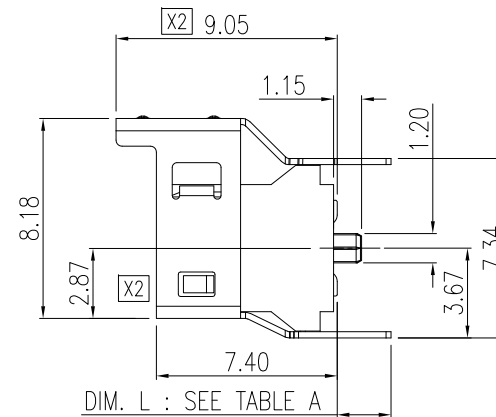
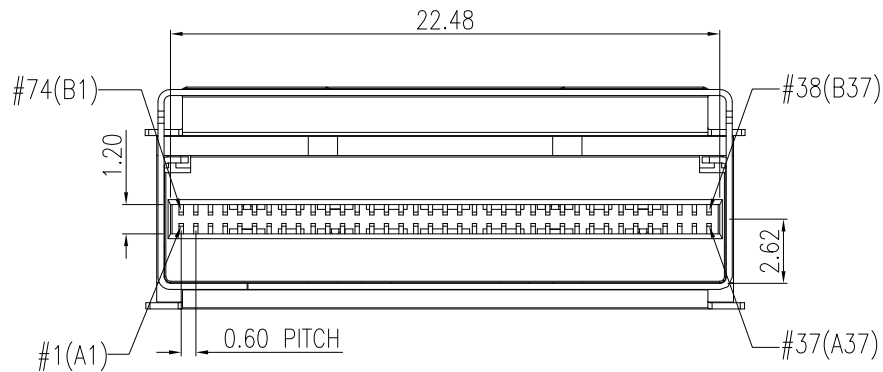
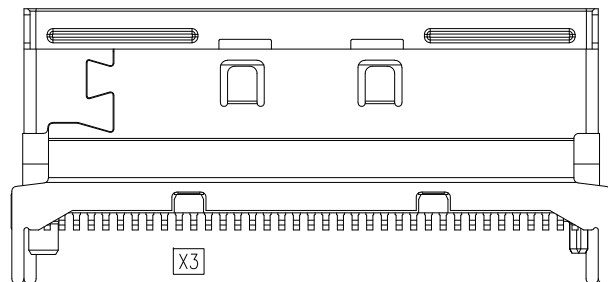

TABLE A X2

| PART NUMBER | GOLD PLATING | DIM. L |
|--------------|--------------|--------|
| 230-10085-01 | GOLD 30u" | 1.5mm |
| 230-10085-02 | GOLD 30u" | 2.2mm |
| 230-10085-03 | GOLD 30u" | 3.0mm |
| 230-10085-04 | GOLD 30u" | 4.2mm |
| 230-10085-05 | GOLD 15u" | 1.5mm |
| 230-10085-06 | GOLD 15u" | 2.2mm |
| 230-10085-07 | GOLD 15u" | 3.0mm |
| 230-10085-08 | GOLD 15u" | 4.2mm |



| | | | | |
|--|---|--------------|-------------------|-----------------------------|
| GENERAL TOLERANCE X.± .X±0.40 .XX±0.30 .XXX±0.20 | ANGLE TOLERANCE X'± .X'± .XX'± .XXX'± | DRAWN JOE | DATE 2/20/2021 | |
| MATL SEE BOM | FINISH SEE NOTES | CHECKED | DATE | |
| SCALE N/A | UNIT mm | APPROVED | DATE | PART NUMBER 230-10085-XX |
| SHEET 1 OF 2 | | | | DRAWING NO. 230-10085 |
| | | | | SIZE A4 REV. X4 |

PROPRIETARY INFORMATION
COMPANY CONFIDENTIAL

| REV. | ECN. NO. | DESCRIPTION | ENG | DATE |
|------|----------|-------------|-----|------|
| | | SEE SHEET 1 | | |

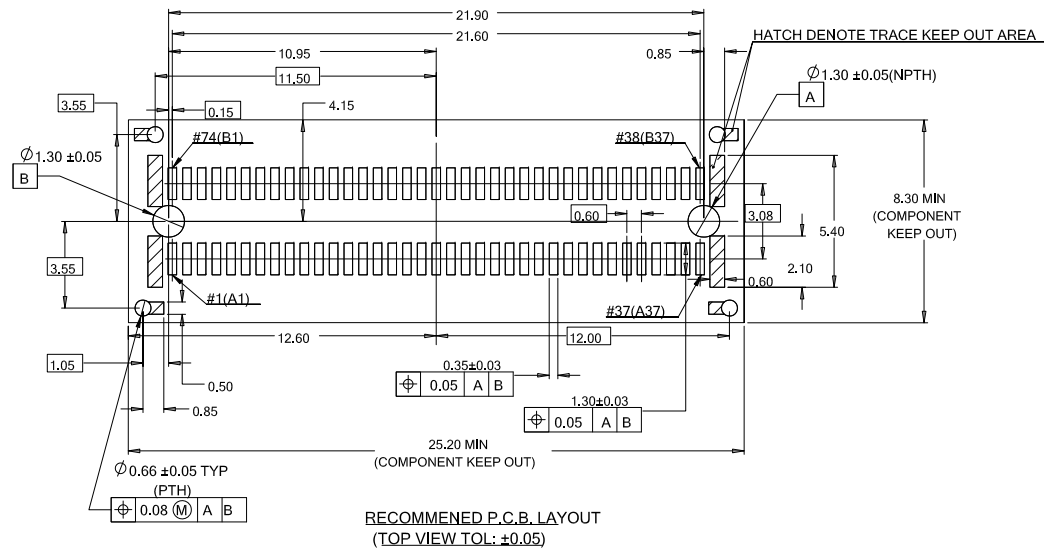

| | | | | | |
|--|---|--------------|-------------------|--------------------------|--|
| GENERAL TOLERANCE X.± .X±0.40 .XX±0.30 .XXX±0.20 | ANGLE TOLERANCE X'± .X'± .XX'± .XXX'± | DRAWN JOE | DATE 2/20/2021 | | TITLE SLIMSAS 8i VERTICAL 85ohm LP, PIN OUTSIDE, RECEPTACLE |
| MATL SEE BOM | FINISH SEE NOTES | CHECKED | DATE | | PART NUMBER. 230-10085-XX |
| SCALE N/A | UNIT mm | APPROVED | DATE | DRAWING NO. 230-10085 | SIZE A4 REV. X4 |
| SHEET 2 OF 2 | | | | | |