

PROPRIETARY INFORMATION
COMPANY CONFIDENTIAL

REV.	ECN. NO.	DESCRIPTION	ENG	DATE
X1		INITIAL	AXL	6/1/2018
X2		UPDATED DWG	Luck Tao	12/20/2018
X3		UPDATE NOTE	Joy	09/10/2021

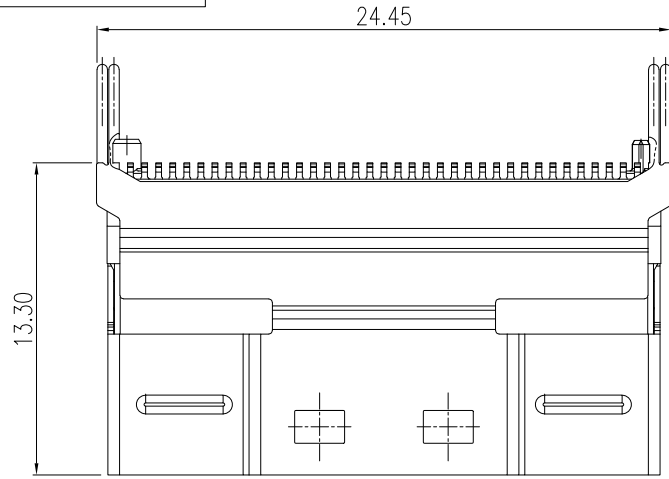

NOTES:

MATERIAL:

- 1: HOUSING: SOLDER REFLOW PROCESS COMPATIBLE LCP, UL94V-0
- CONTACTS: HIGH PERFORMANCE COPPER ALLOY
- SHELL: SUS
- 2: ROHS COMPLIANT

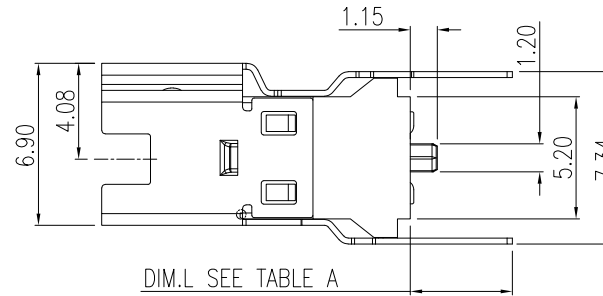
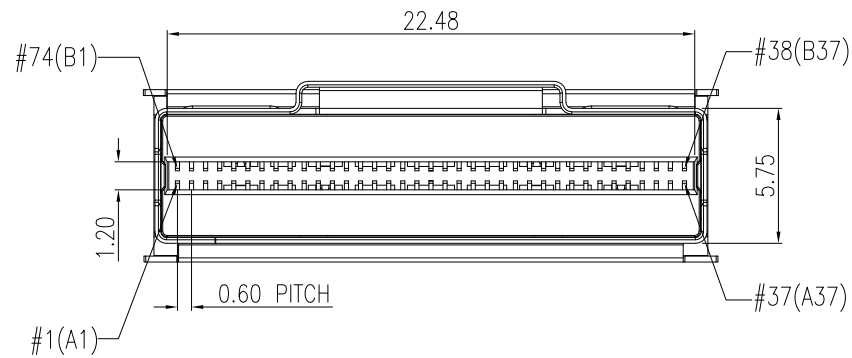
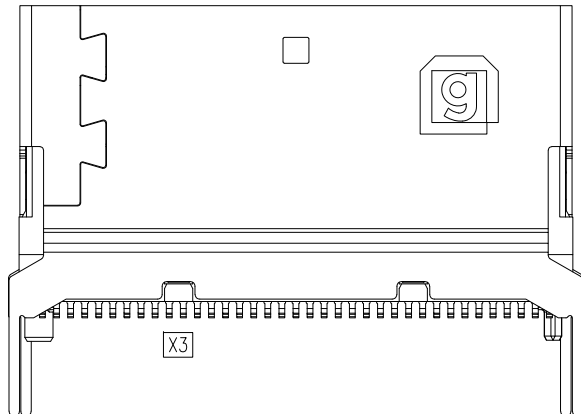
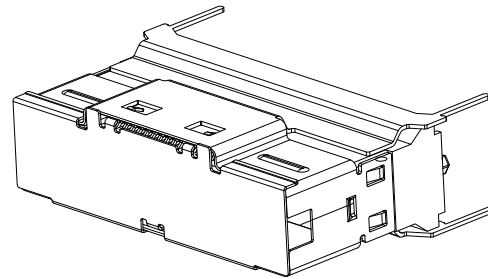

TABLE A

PART NUMBER	GOLD PLATING	DIM. L
230-10057-01	GOLD 30u"	1.5mm
230-10057-02	GOLD 30u"	2.2mm
230-10057-03	GOLD 30u"	3.0mm
230-10057-04	GOLD 30u"	4.2mm
230-10057-05	GOLD 15u"	1.5mm
230-10057-06	GOLD 15u"	2.2mm
230-10057-07	GOLD 15u"	3.0mm
230-10057-08	GOLD 15u"	4.2mm



GENERAL TOLERANCE X.± .X±0.40 .XX±0.30 .XXX±0.20	ANGLE TOLERANCE X°± .X°± .XX°± .XXX°±	DRAWN Luck Tao	DATE 12/20/18		TITLE: SLIMSAS 8i VERTICAL 85ohm THRU PIN OUTSIDE, RECEPTACLE
MATL SEE BOM	FINISH SEE NOTES	CHECKED	DATE		PART NUMBER. 230-10057-XX
SCALE N/A	UNIT mm	APPROVED	DATE	DRAWING NO. 230-10057	SIZE A4 REV. X3
SHEET 1 OF 2					

PROPRIETARY INFORMATION
COMPANY CONFIDENTIAL

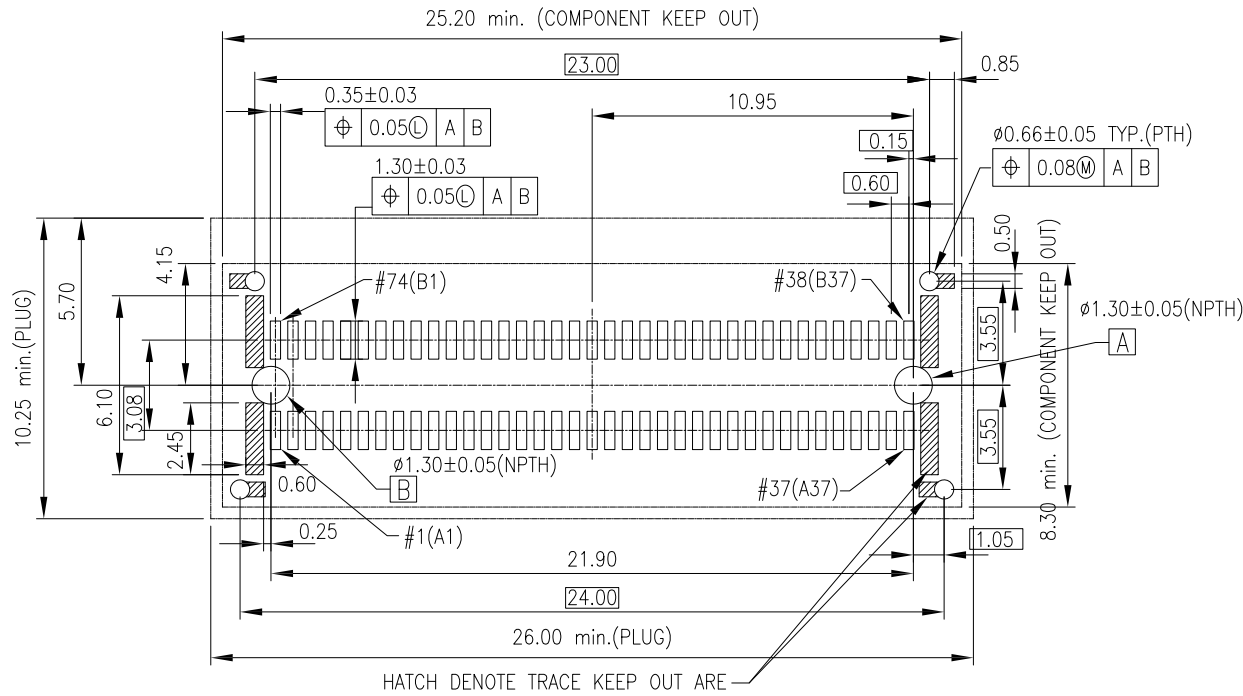

RECOMMENDED PCB LAYOUT
COMPONENT SIDE

GENERAL TOLERANCE $X \pm$ $.X \pm 0.40$ $.XX \pm 0.30$ $.XXX \pm 0.20$		ANGLE TOLERANCE $X^\circ \pm$ $.X^\circ \pm$ $.XX^\circ \pm$ $.XXX^\circ \pm$		DRAWN Luck Tao DESIGN	DATE 12/20/18 DATE		TITLE: SLIMSAS 8i VERTICAL 85ohm THRU PIN OUTSIDE, RECEPTACLE
MATL SEE BOM		CHECKED DATE		PART NUMBER. 230-10057-XX			
FINISH SEE NOTES		APPROVED DATE		DRAWING NO. 230-10057		SIZE A4	REV. X3
SCALE N/A		UNIT mm		SHEET 2 OF 2			