

REV.	ECN. NO.	DESCRIPTION	ENG	DATE
X1		INITIAL	TERRY	05/31/18'
X2		ADD HOUSING COLOUR	LEO	10/01/22'
X3		CHANGE SHIELD PLATING SPEC	TERRY	11/09/22'

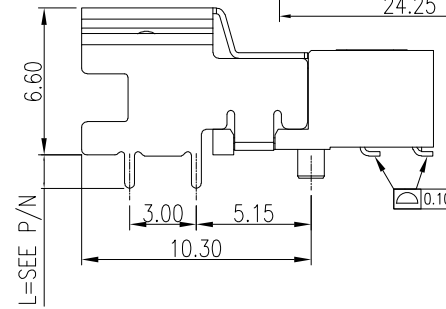
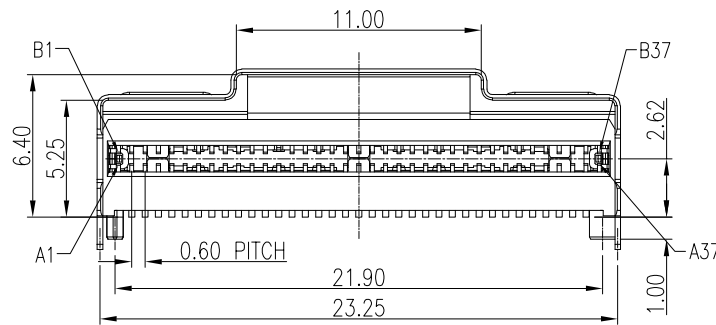
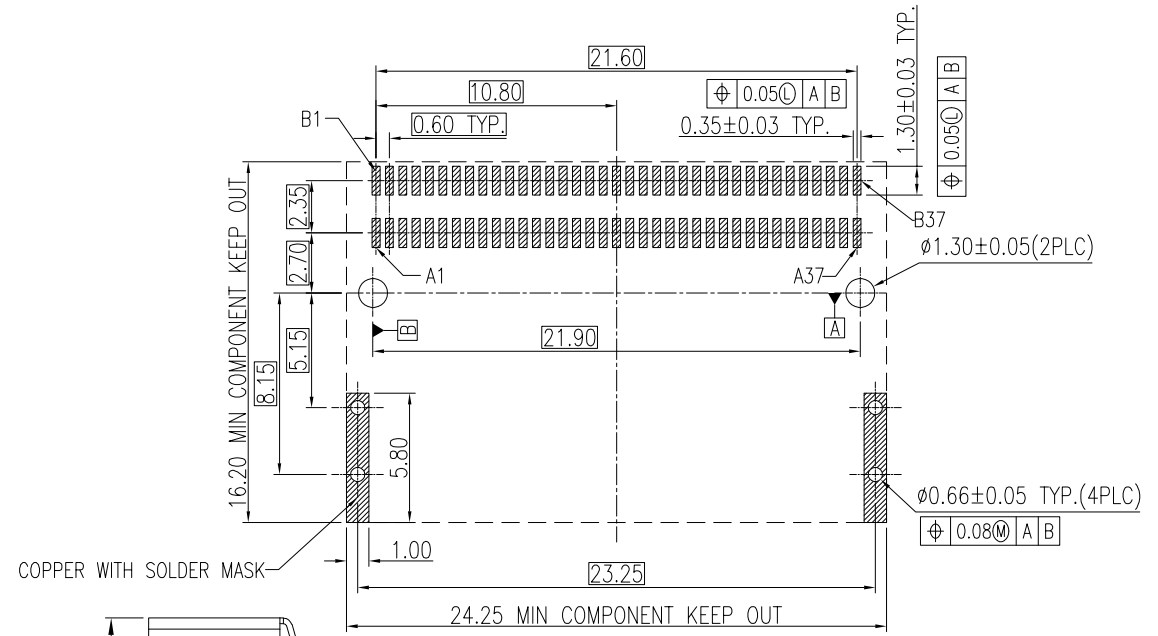
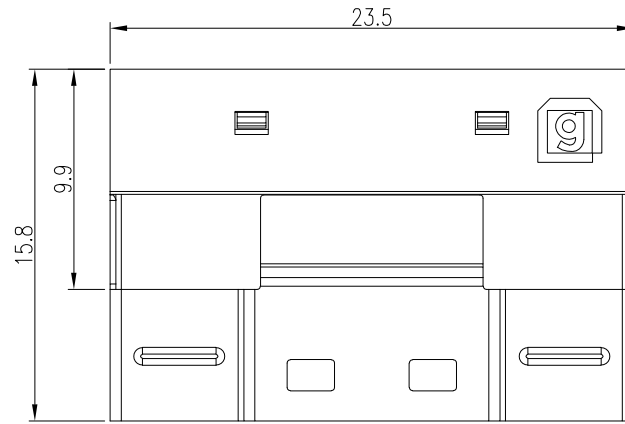

NOTES:
MATERIAL:

- HOUSING: SOLDER REFLOW PROCESS COMPATIBLE LCP, BLACK, UL94V-0
- CONTACTS: HIGH PERFORMANCE COPPER ALLOY
- SHELL: SUS; NICKEL PLATED OVERALL
- ROHS COMPLIANT

PART NUMBER

PART NUMBER	GOLD PLATING	DIM. L
230-10047-01	GOLD 30u"	1.5mm
230-10047-02	GOLD 30u"	2.2mm
230-10047-03	GOLD 30u"	3.0mm
230-10047-04	GOLD 30u"	4.2mm
230-10047-05	GOLD 15u"	1.5mm
230-10047-06	GOLD 15u"	2.2mm
230-10047-07	GOLD 15u"	3.0mm
230-10047-08	GOLD 15u"	4.2mm

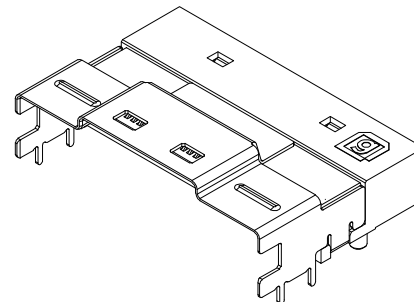
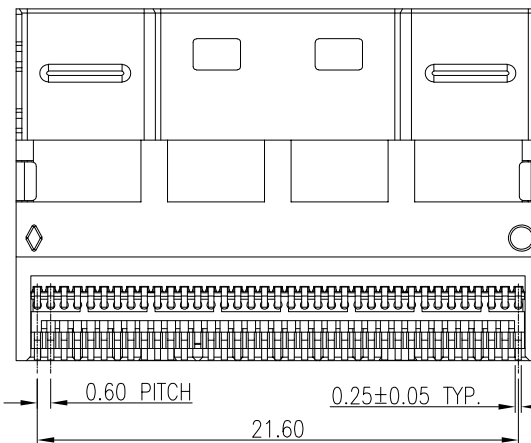

GENERAL TOLERANCE X± .X±0.35 .XX±0.25 .XXX±0.15	ANGLE TOLERANCE X°± .X°± .XX°± .XXX°±	DRAWN Terry	DATE 5/31/18'
MATERIAL		CHECKED	DATE
FINISH		APPROVED	DATE
SCALE N/A	UNIT mm		
SHEET 1 OF 1			

TITLE. SLIMSAS 8i R/A 85 ohm THRU PIN SHILED RECEPTACLE	
PART NUMBER. 230-10047-XX	
DRAWING NO. 230-10047	SIZE A4 REV. X3