

- NOTE(注释):
- CABLE ASSEMBLY IMPEDANCE: 100±10 ohm.
成品特性阻抗: 100±10 欧姆
 - 100% CONDUCTOR TEST, TEST CONDITION:VOLTAGE 5V,INSULTION RESISTANCE 10M ohm,
CONDUCTION RESISTANCE MAX 3 ohm
100% 导通测试, 测试条件为电压5V, 绝缘10M欧姆, 导通电阻不大于3欧姆
 - HIGH-FREQUENCY TEST ACCORDING TO IEEE802.3 STANDARD.
高频测试依照IEEE802.3标准测试
 - ALL MATERIAL MUST COMPLY WITH ROHS2.0.
所有物料必须符合ROHS2.0

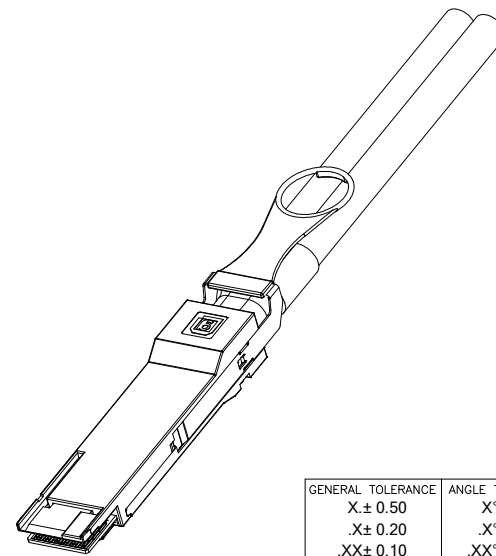

13	CABLE LABEL	LABEL, 48.3*79.2mm	2
12	DUST COVER(防尘盖)	LDPE, NATURAL	2
11	INNER MOLD(内模)	HOT-MELT GLUE	A/R
10	HEAT SHRINKABLE TUBE(热缩套管)	Ø17MM,	A/R
9	COPPER FOIL (铜箔)	6.4X0.05mm	2
8	SCREW(螺丝)	SUS304	4
7	SPRING(弹簧)	SWPB	4
6	PULL TAB(拉带)	PA66 S1300, BLACK	2
5	LATCH(挂钩)	STAINLESS STEEL	2
4	BOTTOM SHELL(下壳)	Zn ALLOY, PLATED Ni OVER Cu	2
3	TOP SHELL(上壳)	Zn ALLOY, PLATED Ni OVER Cu	2
2	PCB ASSEMBLY(PCB 成品)	QSFP-DD, PCB, 76P, Au 30u*Min	2
1	RAW CABLE(线材)	TWINAX, 8PAIRS, BLACK, 100ohms TABLE A	A/R
ITEM	NAME	DESCRIPTION	Q'TY

GENERAL TOLERANCE .X± 0.50 .X± 0.20 .XX± 0.10 .XXX± 0.05	ANGLE TOLERANCE X°± 5.0° .X°± 3.0° .XX°± 2.0° .XXX°± 1.0°	DRAWN	DATE	<p>TITLE: QDD-QDD DAC, 56G Active 400G RETIMER MAXLINEAR</p> <p>PART NUMBER: 320-10598-XX</p> <p>DRAWING NO. 320-10598</p> <p>SIZE A4 REV. X1</p>
MATERIAL		CHECKED	DATE	
FINISH		APPROVED	DATE	
SCALE N/A	UNIT mm			
SHEET 1 OF 3				

WIRING TABLE

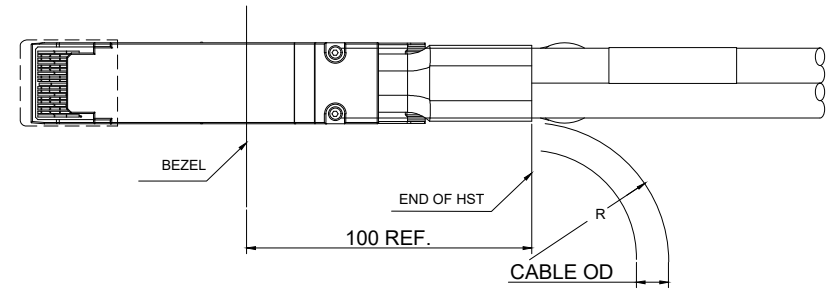
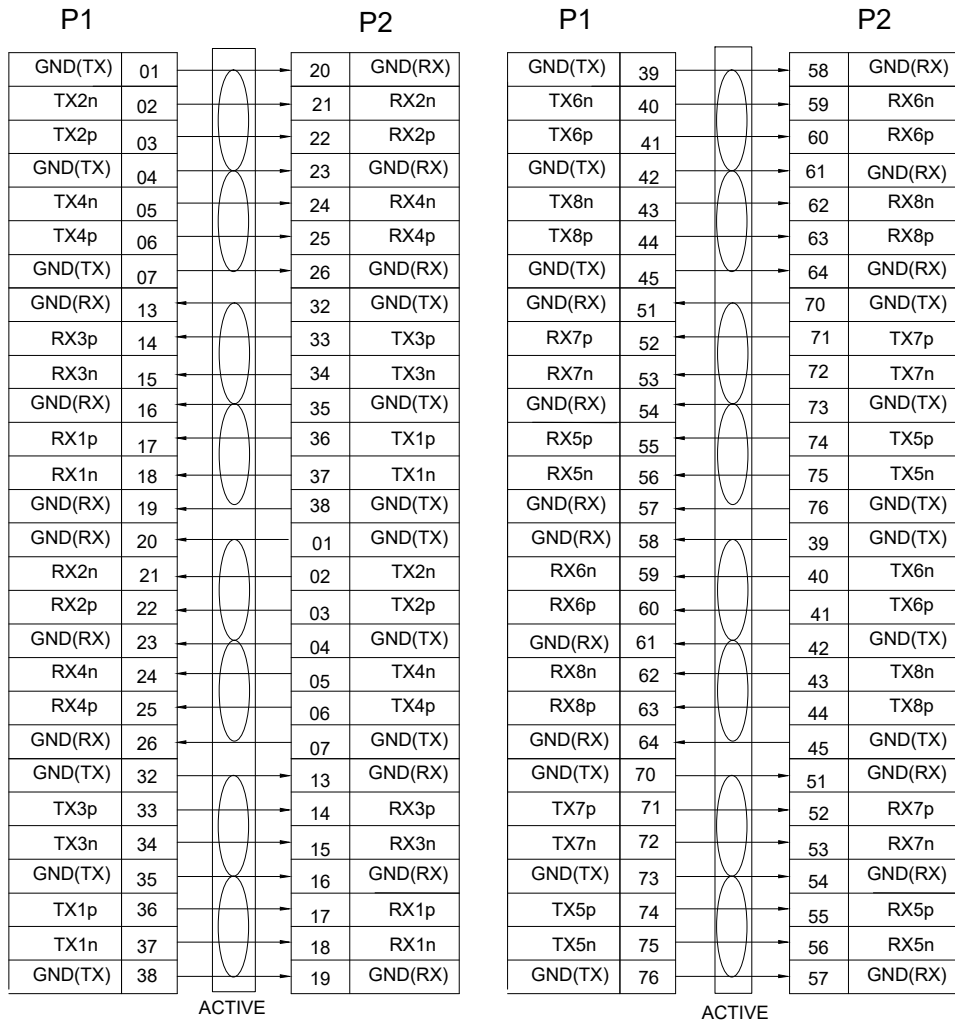

CABLE GAUGE	CABLE "OD"	STATIC BEND RADIUS "R"	DYNAMIC BEND RADIUS "R"
30AWG	6.7MM	33.5MM	67MM
28AWG	7.9MM	39.5MM	79MM

GENERAL TOLERANCE X.± 0.50 .X± 0.20 .XX± 0.10 .XXX± 0.05	ANGLE TOLERANCE X°± 5.0° .X°± 3.0° .XX°± 2.0° .XXX°± 1.0°	DRAWN	DATE		
MATERIAL		CHECKED	DATE		TITLE QDD-QDD DAC, 56G Active 400G RETIMER MAXLINEAR
FINISH		APPROVED			PART NUMBER 320-10598-XX
SCALE <i>N/A</i>	UNIT <i>mm</i>	DATE			DRAWING NO. 320-10598
SHEET 2 OF 3				SIZE <i>A4</i> REV. <i>X1</i>	

PROPRIETARY INFORMATION
COMPANY CONFIDENTIAL

REV.	ECN. NO.	DESCRIPTION	ENG	DATE
		REFER TO PAGE 1		

TABLE A				
PART NUMBER	WIRE TYPE	xx AWG	XM1 LENGTH	XM2 LENGTH
320-10598-01	PVC	30	1000±20	
320-10598-02	PVC	30	2000±30	
320-10598-03	PVC	30	3000±30	
320-10598-04	PVC	30	4000±30	
320-10598-05	PVC	28	5000±30	
320-10598-06	PVC	28	5500±30	

CABLE LABEL:



QDD-QDD DAC, 400G xxAWG XMx

PN: 320-10598-XX REV XX



S/N: XXXXXXXXxxxx

S/N: YYMDDLLnnnn

DIMENSION 1 OR 2
LENGTH IN METERS
WIRE GAUGE



PN AND REV,

128code:
XXXXXXXXxxxxx

4位流水号

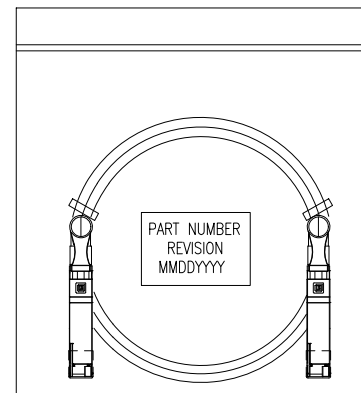
PACKAGING:



GENERAL TOLERANCE X.± 0.50 .X± 0.20 .XX± 0.10 .XXX± 0.05	ANGLE TOLERANCE X°± 5.0° .X°± 3.0° .XX°± 2.0° .XXX°± 1.0°	DRAWN	DATE	 genesis connected solutions
MATERIAL		CHECKED	DATE	
FINISH		APPROVED		PART NUMBER 320-10598-XX
SCALE N/A	UNIT mm			DRAWING NO. 320-10598
SHEET 3 OF 3				SIZE A4 REV X1