

PROPRIETARY INFORMATION  
COMPANY CONFIDENTIAL

REV.	ECN. NO.	DESCRIPTION	ENG	DATE
X1		INITIAL	ZAKK	6/8/2022

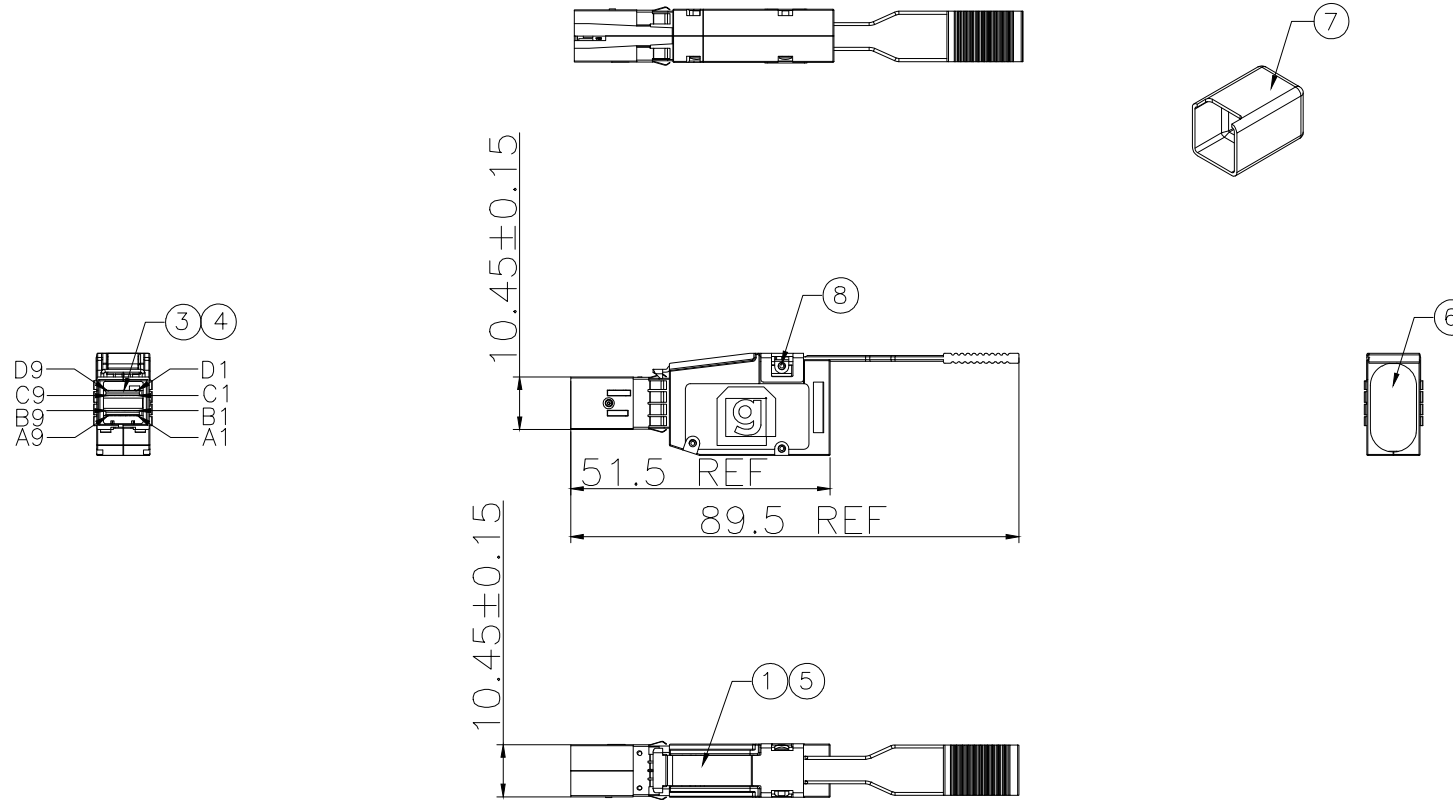

7	P-HSEPE-0001	1	DUST COVER FOR SFF-8644, PE, NATUAL	
6	M-HSETPNI-01	1	PLUG BOARD	
5	P-HSEPE-0002	1	INNER MOLDING FOR EXT HD-SAS,	
4	P-HSE2830-02B	1	EXT MINI SAS HD PCB A,B	
3	A-HSE2830-01B	1	EXT MINI SAS HD PCB C,D	
2	SHSE30-1-G	1	EXT HD-SAS CONNECTOR,SHELL,LATCH,PULL TAB,RIVET,EMI	
1	CAB-MSI-D-30MN	R/A	2P 30AWG CABLE	
ITEM	NAME	Q'TY	DESCRIPTION	NOTE

GENERAL TOLERANCE	ANGLE TOLERANCE
<b>X±0.50</b>	<b>X°±5.0°</b>
<b>.X±0.20</b>	<b>.X°±3.0°</b>
<b>.XX±0.10</b>	<b>.XX°±2.0°</b>
<b>.XXX±0.05</b>	<b>.XXX°±1.0°</b>
MATL	SEE BOM
FINISH	SEE NOTES
SCALE <i>N/A</i>	UNIT <i>mm</i>
SHEET 1 OF 2	

DRAWN	DATE
HSIO	2016.07.21
CHECKED	DATE
APPROVED	DATE

RoHS Compliant	
TITLE: EXT MINI SAS HD LOOPBACK SFF-8644 , 24G	
PART NUMBER: 320-10552-XX	
DRAWING NO.	SIZE
320-10552	A4
	REV. X1

1 2 3 4 5 6 7 8

A B C D E

A B C D E

1 2 3 4 5 6 7 8

WIRING TABLE

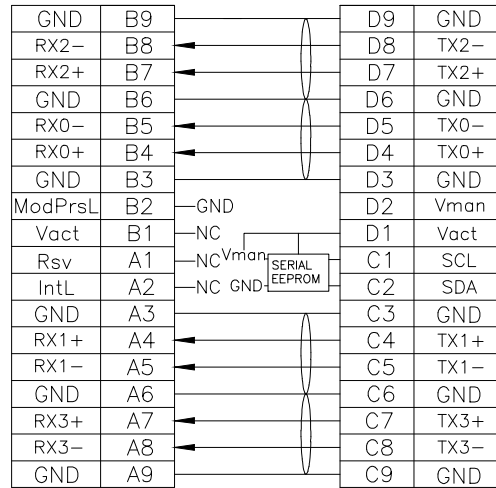

MATERIAL RoHS COMPLIANT:

1. PCB: ISOLA 370HR
2. LEFT /RIGHT SHELL: ZINC ALLOY NICKEL PLATED
3. THIS PRODUCT CONFORMS TO THE MECHANICAL DIMENSIONING REQUIREMENTS OF SFF-8644
4. ELECTRICAL TEST PLS REFER TO SLK STANDARD ES-005
5. TWO-WIRED SERIAL MEMORY: AT24C02B EEPROM(256 BYTES)
6. THIS PRODUCT MEETS SAS4.0

RoHS Compliant

GENERAL TOLERANCE <b>X±0.50</b> <b>.X±0.20</b> <b>.XX±0.10</b> <b>.XXX±0.05</b>	ANGLE TOLERANCE <b>X°±5.0°</b> <b>.X°±3.0°</b> <b>.XX°±2.0°</b> <b>.XXX°±1.0°</b>	DRAWN HSIO	DATE 2016.07.21		TITLE EXT MINI SAS HD LOOPBACK SFF-8644 ,24G
MATERIAL SEE BOM		CHECKED	DATE		PART NUMBER 320-10552-XX
FINISH SEE NOTES		APPROVED	DATE	DRAWING NO. 320-10552	SIZE A4
SCALE N/A	UNIT mm	SHEET 2 OF 2			REV. X1