

REV.	ECN. NO.	DESCRIPTION	ENG	DATE
X1		ISSUED	DANIEL	01/21/13'
X2		ADD NOTES 1	DANIEL	01/24/13'

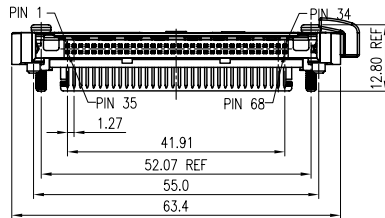
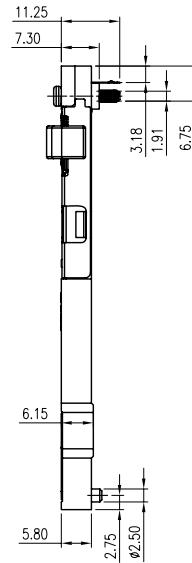
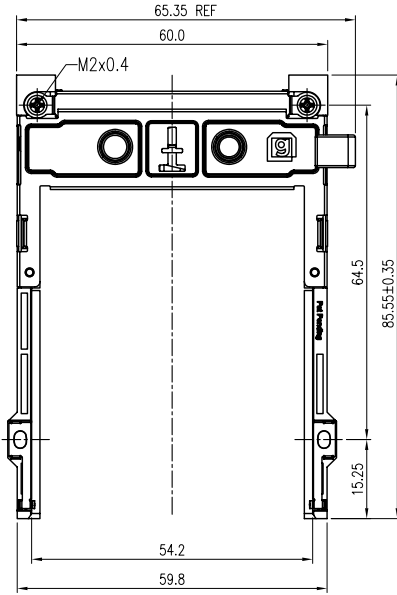

PIN TYPE	PIN NUMBER
DETECT: 3.50mm	36&67
GENERAL: 4.25mm	THE REST
POWER: 5.00mm	1&17&34&35&51&68

NOTES:

- MATERIALS:
HOUSING: PBT+30% G.F. UL94V-0, COLOR: BLACK
 KNOB COLOR: GREEN PMS 361C
CONTACTS: COPPER ALLOY
- FINISH:
CONTACTS: GOLD PLATED OPTIONAL (SEE PART. NUMBER)
PLATE NICKEL 50u" MIN OVER ALL SURFACE
- MATES WITH PCMR-1068 SERIES
- RECOMMENDED SCREW TORQUE : 1.8 kgf.cm Max.
- RoHS 6/6 COMPLIANT.

PART. NUMBER

PCMR-29 68 - A K * 0 I 01
① ② ③④⑤⑥⑦

- CONNECTOR:
PCMR-29: 68PIN PCMCIA, SOCKET
- POSITION:
68: 68 POSITIONS
- INSULATOR MATERIAL:
A: PBT
- INSULATOR COLOR:
K: BLACK
- CONTACT PLATING:
1: GOLD FLASH
- SHIELD PLATING
0: NONE-SHIELD
- PACKING
T: TRAY

GENERAL TOLERANCE X.±0.50 .X±0.38 .XX±0.25 .XXX±0.15	ANGLE TOLERANCE X°± 2° .X°± 1° .XX°± .XXX°±	DRAWN DANIEL	DATE 01/24/13'		TITLE: 68PIN PCMCIA SOCKET CONNECTOR
MATL SEE BOM	FINISH SEE NOTES	CHECKED	DATE		PART NUMBER. PCMR-2968-AKX0T01
SCALE N/A	UNIT mm	APPROVED	DATE	DRAWING NO. GT17-250144	SIZE A4 REV. X2
SHEET 1 OF 1					