

PROPRIETARY INFORMATION
COMPANY CONFIDENTIAL

REV.	ECN. NO.	DESCRIPTION	ENG	DATE
A		INITIAL	Knight	03/22/16'

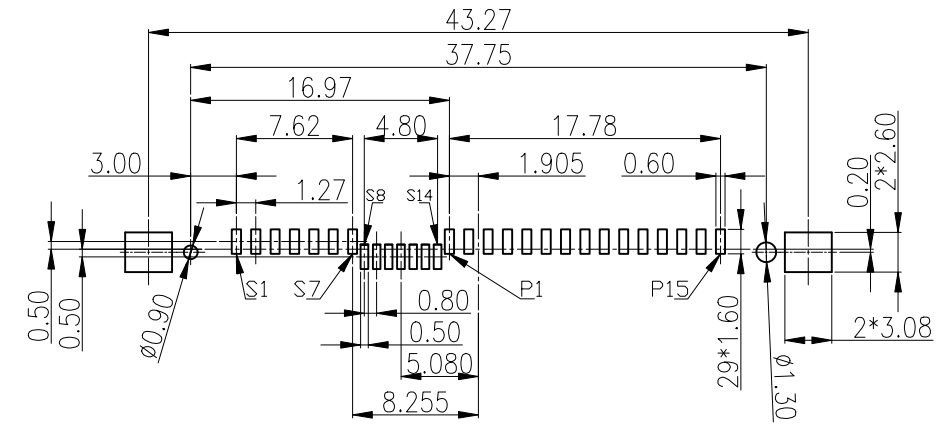
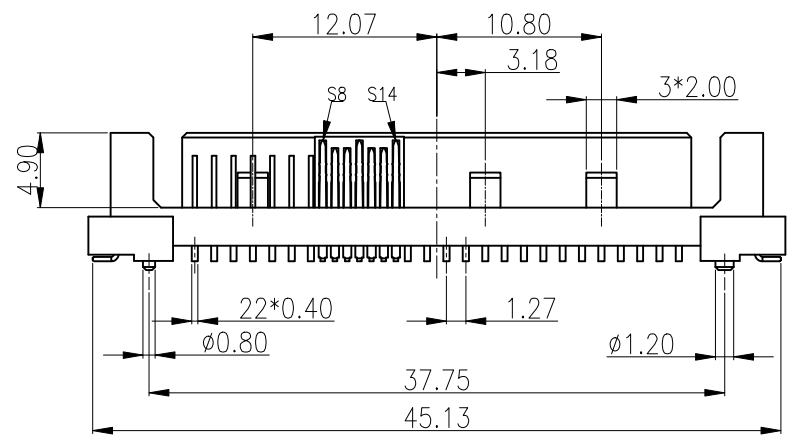
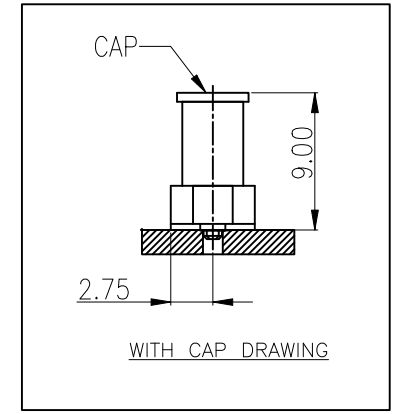
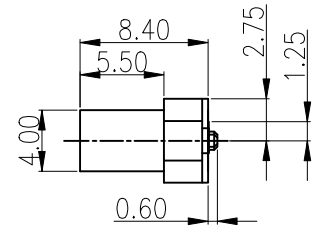
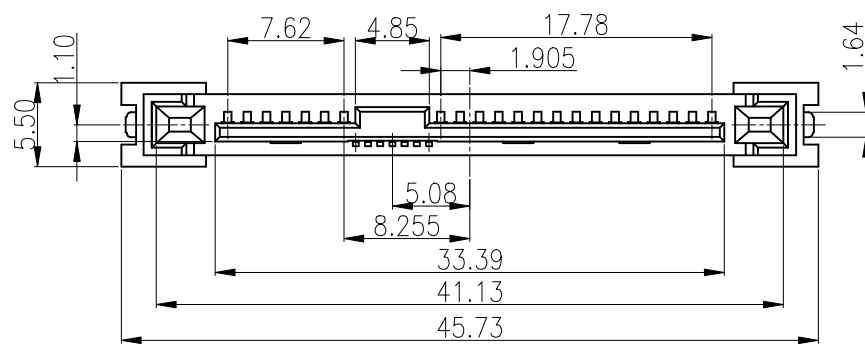
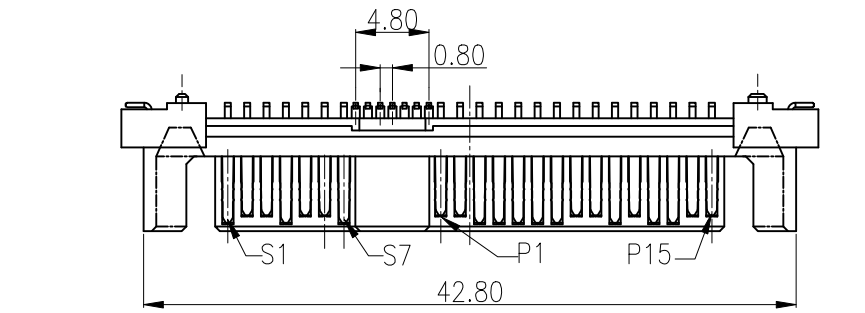

PCB LAYOUT (TOP VIEW)

3	BOARD LOCK	2	SPCC, TIN 80u" MIN PLATING OVERALL
2	CONTACT	29	BRASS, GOLD 15u" PLATING ON CONTACT AREA, TIN 40u" MIN PLATING SOLDER AREA, NICKEL 50u" MIN UNDER PLATING OVERALL
1	HOUSING	1	LCP
ITEM	NAME	Q'TY	DESCRIPTION

GENERAL TOLERANCE		ANGLE TOLERANCE		DRAWN	DATE
X ± 0.50		X° ± 5.0°		Knight	03/22/16'
.X ± 0.38		.X° ± 3.0°		CHECKED	DATE
.XX ± 0.25		.XX° ± 2.0°		APPROVED	DATE
.XXX ± 0.15		.XXX° ± 1.0°		River	03/22/16'
MATERIAL		SEE BOM			
FINISH		SEE NOTES			
SCALE	N/A	UNIT	mm		
SHEET	1 OF 1				
NOTE		BLACK, UL94 V-0			

		TITLE: SAS 22+7PIN MALE CONN. H=8.40MM STRAIGHT	
		PART NUMBER: 230-10017-01	
DRAWING NO. 230-10017		SIZE A4 REV. A	