

PROPRIETARY INFORMATION
COMPANY CONFIDENTIAL

REV	ECN. NO.	DESCRIPTION	ENG	DATE
A		INITIAL	Knight	06/19/15'

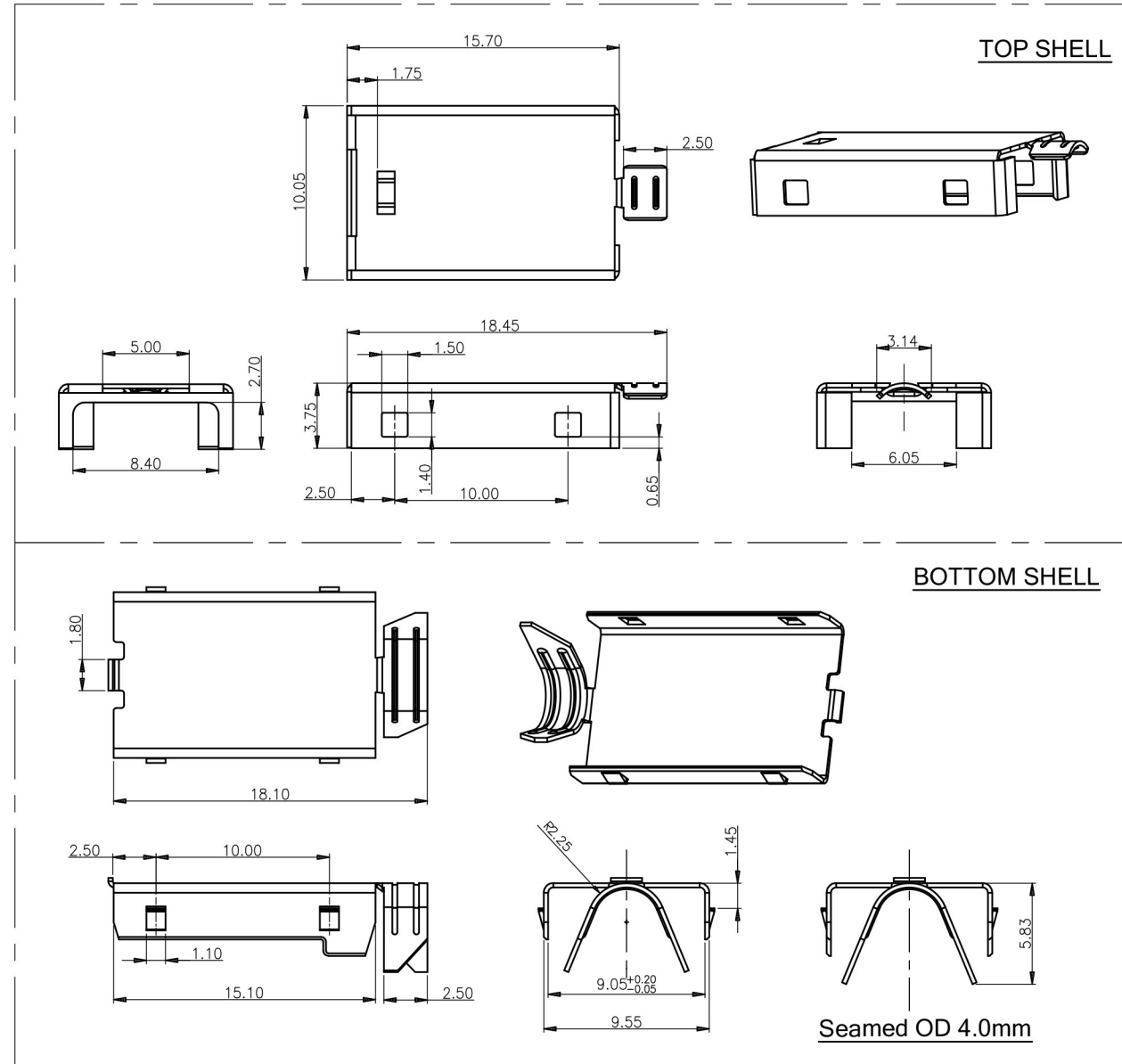

ORDER INFORMATION

USCW-14 00 - 0 0 Y 3 I
① ② ③④⑤⑥⑦

- TYPE:
USCW-14:USB C TYPE PLUG SHELL
- POSITIONS:
00: NONE POSITIONS
- INSULATOR MATERIAL:
0: NONE INSULATOR
- INSULATOR COLOR:
0: NONE INSULATOR
- CONTACT PLATING:
Y: NONE CONTACT
- SHIELD PLATING:
3: NICKEL PLATING
- PACKING
T: TRAY

GENERAL TOLERANCE X ± 0.50 .X ± 0.38 .XX ± 0.25 .XXX ± 0.15	ANGLE TOLERANCE X° ± 5.0° .X° ± 3.0° .XX° ± 2.0° .XXX° ± 1.0°	DRAWN <i>knighe</i> DATE 06/19/15'	 GENESIS TECHNOLOGY, INC. TITLE: USB C-TYPE PLUG SHELL PART NUMBER: USCW-1400-00Y3T DRAWING NO. GT26-210508 SIZE A4 REV. A
MATL: SEE BOM	FINISH SEE NOTES	CHECKED DATE	
SCALE <i>N/A</i>	UNIT <i>mm</i>	APPROVED <i>River</i> DATE 06/19/15'	
SHEET 1 OF 1			

ITEM	NAME	Q'TY	DESCRIPTION	NOTE
2	BOTTOM SHELL	1	SPCC,NICKEL 50u"MIN PLATING OVERALL	
1	TOP SHELL	1	SPCC,NICKEL 50u"MIN PLATING OVERALL	