

PROPRIETARY INFORMATION
COMPANY CONFIDENTIAL

REV.	ECN. NO.	DESCRIPTION	ENG	DATE
A		INITIAL	Sunny	02/05/15'

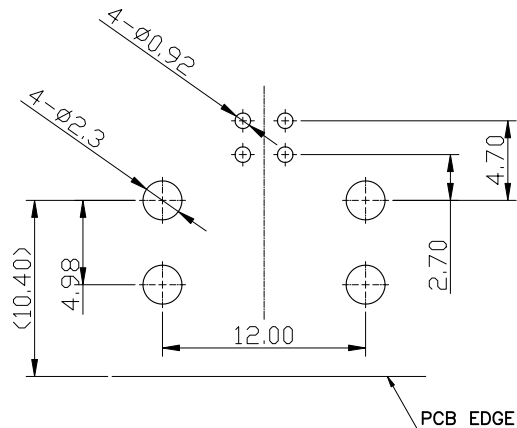
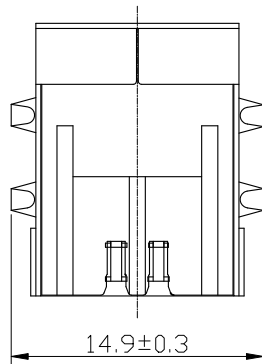
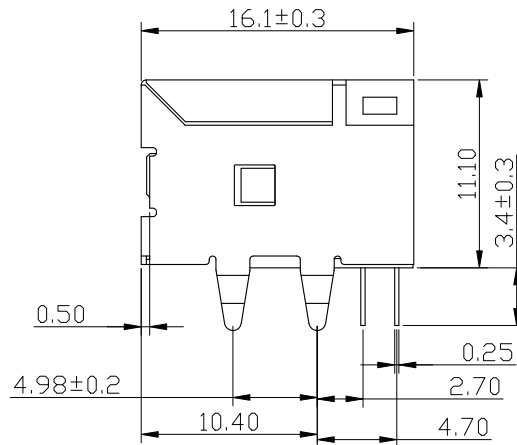
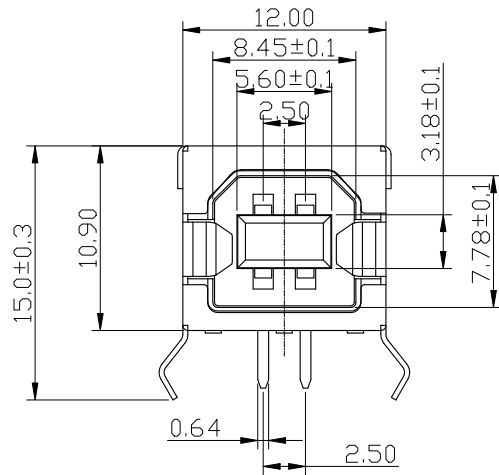

RECOMMENDED P.C.B LAYOUT (COMPONENT SIDE)
P.C.B THICKNESS=1.60MM (TOLERANCE=±0.05)

- NOTE:
- CONTACT CURRENT: 1.5A AT 250V AC MIN.
 - CONTACT RESISTANCE: 30mΩ MAX.
 - INSULATION RESISTANCE: 1000MΩ MIN
 - WITHSTAND VOLTAGE: 500V AC MAX WITH 1 MINUTE
 - VOLTAGE RATING: 30V DC
 - OPERATING TEMPERATURE: -30°C TO +85°C
 - INSERTION FORCE : 3.5(KG)MAX.
 - EXTRACTION FORCE : 1.0(KG)MAX.
 - RoHS 6/6 COMPLIANT.

PART NUMBER:

USBR-25 04-A K 1 3 T
① ② ③ ④ ⑤ ⑥ ⑦

- CONNECTOR:
USBR-25: USB B TYPE RECEPTACLE RIGHT ANGLE
- POSITIONS:
04: 4 POSITIONS
- INSULATOR MATERIAL:
A: PBT
- INSULATOR COLOR:
K: BLACK
- CONTACT PLATING:
1: GOLD FLASH
- SHIELD PLATING:
3: NICKEL PLATING
- PACKING:
T: TRAY

3	CONTACT	4	BRASS,GOLD FLASH ON CONTACT AREA,TIN 100u"MIN PLATING ON SOLDER TAIL,NICKEL 50u"MIN UNDER PLATING OVERALL.
2	SHELL	1	SPCC,PLATING 80u"MIN NICKEL OVERALL
1	HOUSING	1	PBT+30%GF,COLOR BLACK
ITEM	NAME	Q'TY	DESCRIPTION

UL94-V0
NOTE

GENERAL TOLERANCE	ANGLE TOLERANCE	DRAWN	DATE
X.±0.50	X°± 5.0°	Sunny	02/05/15'
.X±0.38	.X°± 3.0°	CHECKED	DATE
.XX±0.25	.XX°± 2.0°	APPROVED	DATE
.XXX±0.15	.XXX°± 1.0°	River	02/05/15'
MATL	SEE BOM	SCALE	N/A
FINISH	SEE NOTES	UNIT	mm
SHEET	1 OF 1		

TITLE: USB B TYPE RECEPTACLE RIGHT ANGLE	
PART NUMBER: USBR-2504-AK13T	
DRAWING NO. GT26-210390	SIZE A4 REV. A