

PROPRIETARY INFORMATION
COMPANY CONFIDENTIAL

REV	ECN. NO.	DESCRIPTION	ENG	DATE
A		INITIAL	Knight	02/04/15'

NOTES:

1. CURRENT RATING: 1.5A
2. DIELECTRIC WITHSTANDING VOLTAGE: 500V AC MAX
3. INSULATION RESISTANCE: 1000MΩ MIN
4. CONTACT RESISTANCE: 30mΩ MAX
5. INSERTION FORCE: 3.5(KG) MAX
6. EXTRACTION FORCE: 1.0(KG) MIN
7. RoHS COMPLIANCE

ORDER INFORMATION

USAV-2E 04 - A K 1 3 T
① ② ③④⑤⑥⑦

1. TYPE:
USAV-2E:USB A TYPE DIP
2. POSITIONS:
04:04 POSITIONS
3. INSULATOR MATERIAL:
A: PBT
4. INSULATOR COLOR:
K: BLACK
5. CONTACT PLATING:
1: GOLD FLASH
6. SHIELD PLATING:
3: NICKEL PLATING
7. PACKING
T: TRAY

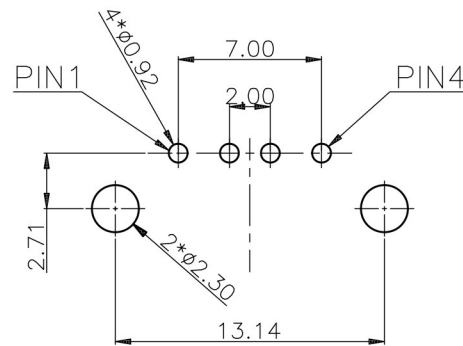
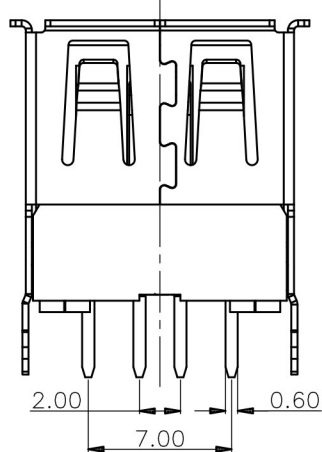
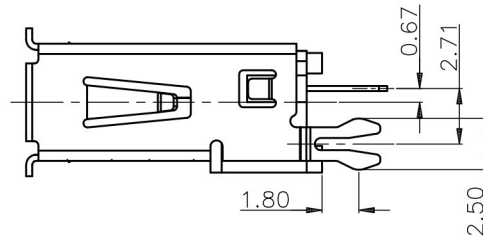
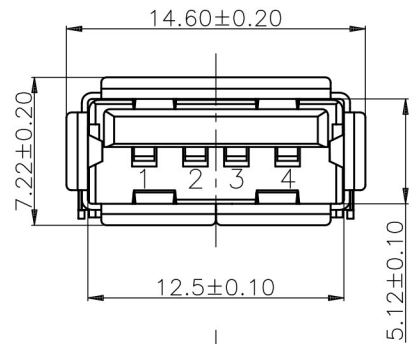
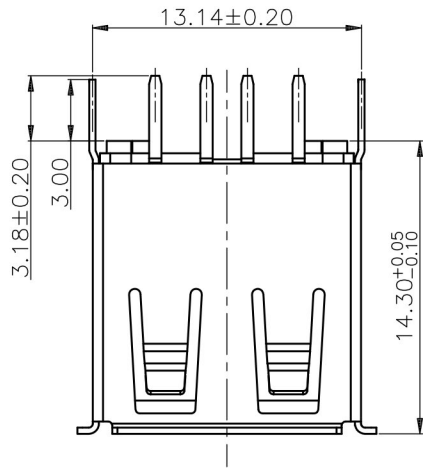

RECOMMENDED P.C.B LAYOUT COMPONENT SIDE
P.C.B THICKNESS=1.20mm TOLERANCE=±0.05

ITEM	NAME	Q'TY	DESCRIPTION
3	SHELL	1	SPCC, NICKEL 80u" MIN PLATING OVERALL
2	CONTACT	4	BRASS, GOLD FLASH PLATING ON CONTACT AREA, TIN 100u" MIN PLATING SOLDER AREA, NICKEL 50u" MIN UNDER PLATING OVERALL
1	HOUSING	1	PBT+30%G.F

BLACK, UL94 V-0
NOTE

GENERAL TOLERANCE X±0.50 .X±0.38 .XX±0.25 .XXX±0.15	ANGLE TOLERANCE X°±5.0° .X°±3.0° .XX°±2.0° .XXX°±1.0°
MATL SEE BOM	FINISH SEE NOTES
SCALE N/A	UNIT mm
SHEET 1 OF 1	

DRAWN <i>hmgne</i>	DATE 02/04/15'
CHECKED	DATE
APPROVED <i>River</i>	DATE 02/04/15'

GENESIS TECHNOLOGY, INC.	
TITLE: USB A TYPE DIP	
PART NUMBER: USAV-2E04-AK13T	
DRAWING NO. GT26-210378	SIZE A4 REV. A