

PROPRIETARY INFORMATION  
COMPANY CONFIDENTIAL

REV	ECN. NO.	DESCRIPTION	ENG	DATE
A		INITIAL	Knight	02/04/15'

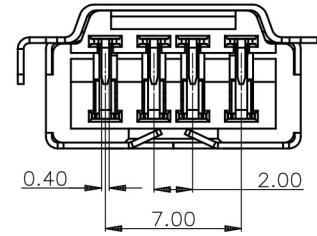
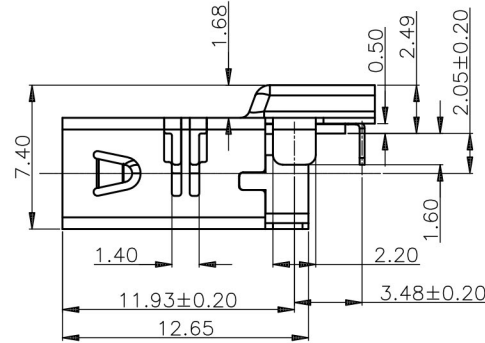
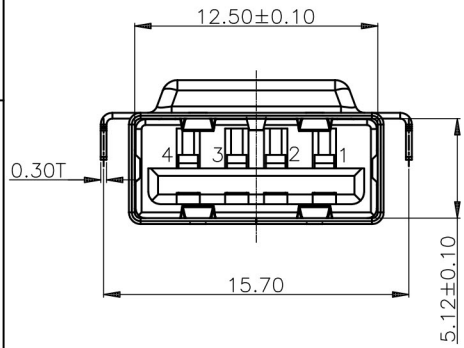

NOTES:

- CURRENT RATING: 1.5A
- DIELECTRIC WITHSTANDING VOLTAGE: 500V AC MAX
- INSULATION RESISTANCE: 100MΩ MIN
- CONTACT RESISTANCE: 30mΩ MAX
- INSERTION FORCE: 3.5(KGF) MAX
- EXTRACTION FORCE: 1.0(KGF) MIN
- RoHS COMPLIANCE

ORDER INFORMATION

USAR-8J 04 - B K 1 3 T  
① ② ③ ④ ⑤ ⑥ ⑦

- TYPE:  
USAR-8J:USB A TYPE REVERSE
- POSITIONS:  
04:04 POSITIONS
- INSULATOR MATERIAL:  
B: LCP
- INSULATOR COLOR:  
K: BLACK
- CONTACT PLATING:  
1: GOLD FLASH
- SHIELD PLATING:  
3: NICKEL PLATING
- PACKING  
T: TRAY

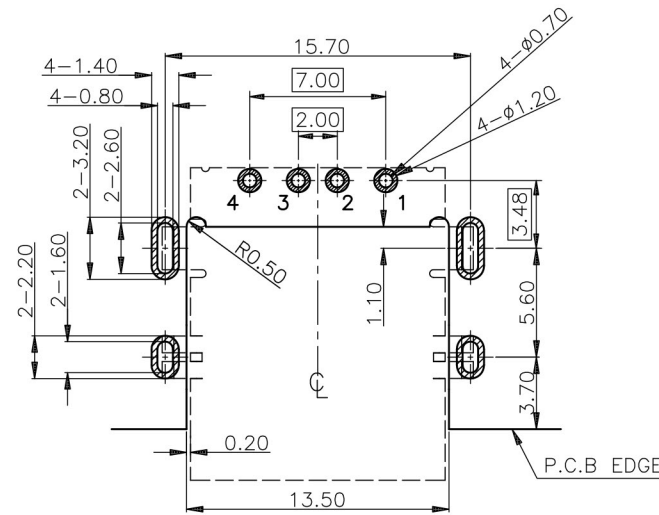
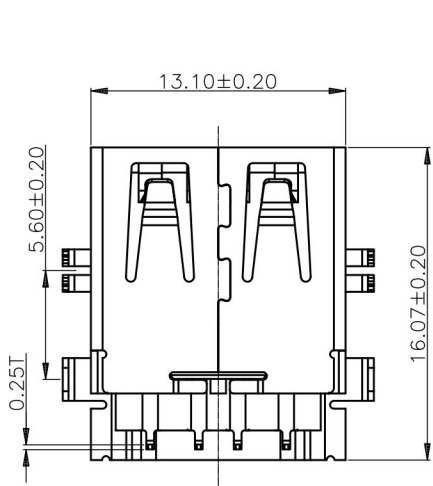

RECOMMENDED P.C.B LAYOUT COMPONENT SIDE  
P.C.B THICKNESS=1.20mm TOLERANCE=±0.03

ITEM	NAME	Q'TY	DESCRIPTION
3	SHELL	1	SPCC, NICKEL 80u" MIN PLATING OVERALL
2	CONTACT	4	BRASS, GOLD FLASH PLATING ON CONTACT AREA, TIN 100u" MIN PLATING SOLDER AREA, NICKEL 50u" MIN UNDER PLATING OVERALL
1	HOUSING	1	LCP+30%G.F

BLACK, UL94 V-0
NOTE

GENERAL TOLERANCE X±0.50 .X±0.38 .XX±0.25 .XXX±0.15	ANGLE TOLERANCE X°±5.0° .X°±3.0° .XX°±2.0° .XXX°±1.0°
MATL SEE BOM	FINISH SEE NOTES
SCALE N/A	UNIT mm
SHEET 1 OF 1	

DRAWN <i>hmgne</i>	DATE 02/04/15'
CHECKED	DATE
APPROVED <i>River</i>	DATE 02/04/15'

<b>GENESIS TECHNOLOGY, INC.</b>	
TITLE: USB A TYPE REVERSE	
PART NUMBER: USAR-8J04-BK13T	
DRAWING NO. GT26-210380	SIZE A4 REV. A