

PROPRIETARY INFORMATION  
COMPANY CONFIDENTIAL

REV.	ECN. NO.	DESCRIPTION	ENG	DATE
A		INITIAL	Knight	02/04/15'
B		ADD CONTACT PLATING OPTION Au 30u"	Knight	05/05/15'

NOTES:

1. CURRENT RATING: 1.5A
2. DIELECTRIC WITHSTANDING VOLTAGE: 500V AC MAX
3. INSULATION RESISTANCE: 1000MΩ MIN
4. CONTACT RESISTANCE: 30mΩ MAX
5. INSERTION FORCE: 3.5(KG) MAX
6. EXTRACTION FORCE: 1.0~2.5(KG) MIN
7. RoHS COMPLIANCE

ORDER INFORMATION

USAR-8E 04 - B K X 3 T  
① ② ③ ④ ⑤ ⑥ ⑦

1. TYPE:  
USAR-8E:USB A TYPE DIP
2. POSITIONS:  
04:04 POSITIONS
3. INSULATOR MATERIAL:  
B: LCP
4. INSULATOR COLOR:  
K: BLACK
5. CONTACT PLATING:  
1: GOLD FLASH  
② 6: GOLD 30u"
6. SHIELD PLATING:  
3: NICKEL PLATING
7. PACKING  
T: TRAY

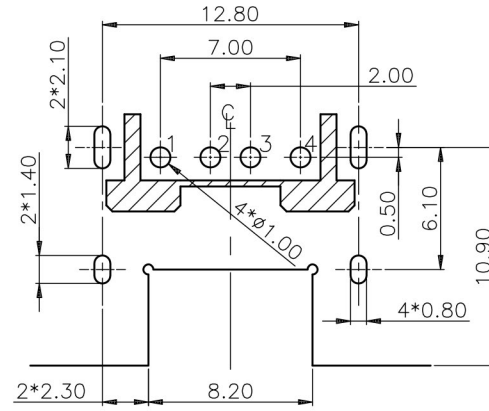
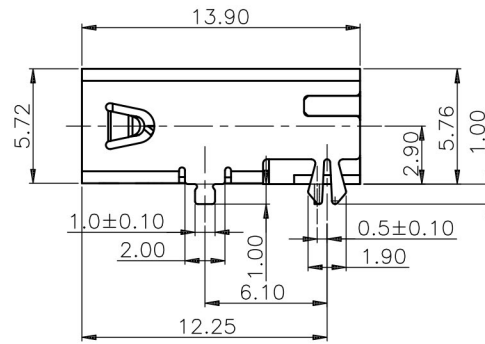
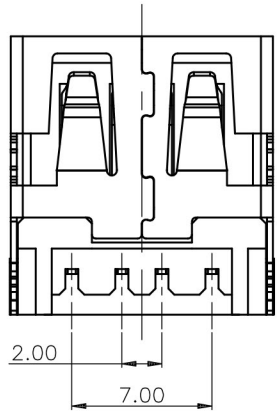
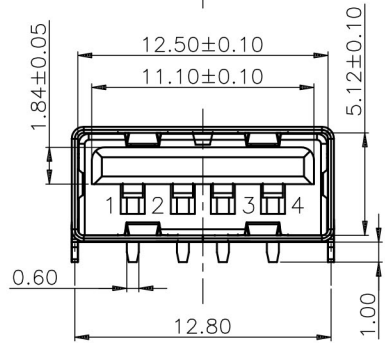
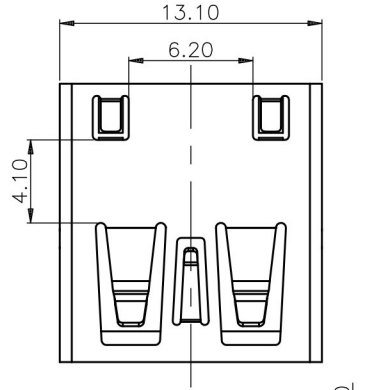

RECOMMENDED P.C.B LAYOUT COMPONENT SIDE  
P.C.B THICKNESS=1.20mm TOLERANCE=±0.05

ITEM	NAME	Q'TY	DESCRIPTION	NOTE
3	SHELL	1	SPCC, NICKEL 80u" MIN PLATING OVERALL	
2	CONTACT	4	BRASS, Au PLATING ON CONTACT AREA, TIN 100u" MIN PLATING SOLDER AREA, NICKEL 50u" MIN UNDER PLATING OVERALL	
1	HOUSING	1	LCP+30%G.F	BLACK, UL94 V-0

GENERAL TOLERANCE	ANGLE TOLERANCE
X±0.50	X°±5.0°
.X±0.38	.X°±3.0°
.XX±0.25	.XX°±2.0°
.XXX±0.15	.XXX°±1.0°

MATL SEE BOM

FINISH SEE NOTES

SCALE N/A UNIT mm

SHEET 1 OF 1

DRAWN	DATE
<i>knighe</i>	05/05/15'
CHECKED	DATE
APPROVED	DATE
<i>River</i>	05/05/15'

<b>GENESIS TECHNOLOGY, INC.</b>	
TITLE: USB A TYPE DIP	
PART NUMBER: USAR-8E04-BKX3T	
DRAWING NO. GT26-210375	SIZE A4 REV. B