

PROPRIETARY INFORMATION  
COMPANY CONFIDENTIAL

REV	ECN. NO.	DESCRIPTION	ENG	DATE
A		INITIAL	Knight	02/04/15'

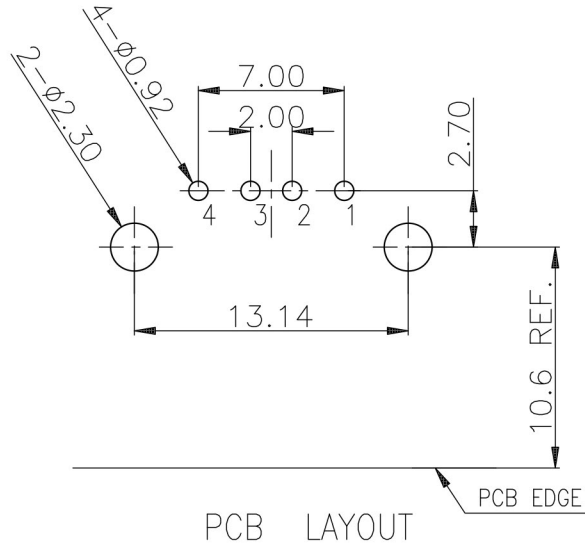

PCB LAYOUT

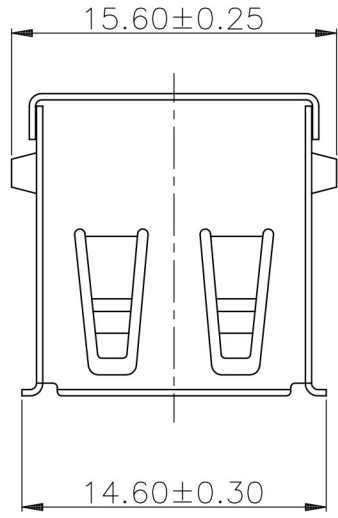
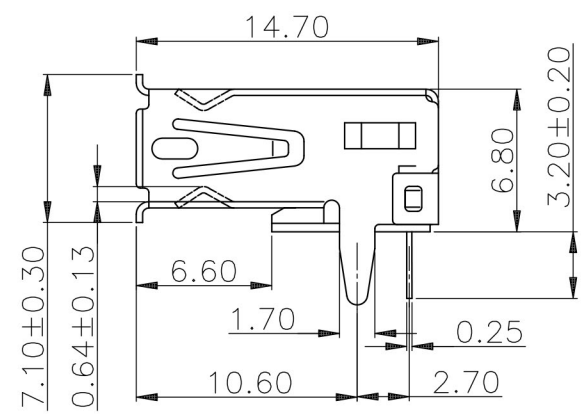
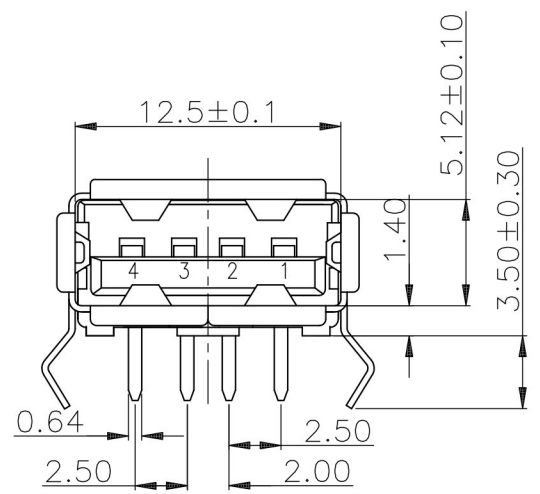

NOTES:

- CURRENT RATING: 1.5A
- DIELECTRIC WITHSTANDING VOLTAGE: 500V AC MAX
- INSULATION RESISTANCE: 1000MΩ MIN
- CONTACT RESISTANCE: 30mΩ MAX
- INSERTION FORCE: 3.5kgf MAX
- EXTRACTION FORCE: 1.0kgf MIN
- RoHS COMPLIANCE

ORDER INFORMATION

USAR-86 04 - A K 1 3 T  
① ② ③ ④ ⑤ ⑥ ⑦

- TYPE:  
USAR-86:USB A TYPE REVERSE
- POSITIONS:  
04:04 POSITIONS
- INSULATOR MATERIAL:  
A: PBT
- INSULATOR COLOR:  
K: BLACK
- CONTACT PLATING:  
1: GOLD FLASH
- SHIELD PLATING:  
3: NICKEL PLATING
- PACKING  
T: TRAY

ITEM	NAME	Q'TY	DESCRIPTION	NOTE
3	SHELL	1	SPCC, NICKEL 80u" MIN PLATING OVERALL	
2	CONTACT	4	BRASS, GOLD FLASH PLATING ON CONTACT AREA, TIN 100u" MIN PLATING SOLDER AREA, NICKEL 50u" MIN UNDER PLATING OVERALL	
1	HOUSING	1	PBT+30%G.F	BLACK, UL94 V-0

GENERAL TOLERANCE X ± 0.50 .X ± 0.38 .XX ± 0.25 .XXX ± 0.15	ANGLE TOLERANCE X° ± 5.0° .X° ± 3.0° .XX° ± 2.0° .XXX° ± 1.0°	DRAWN <i>hngne</i>	DATE 02/04/15'	 <b>TITLE:</b> USB A TYPE REVERSE <b>PART NUMBER:</b> USAR-8604-AK13T <b>DRAWING NO.:</b> GT26-210366	<b>SIZE</b> A4 <b>REV.</b> A
MATL SEE BOM	FINISH SEE NOTES	CHECKED	DATE		
SCALE N/A	UNIT mm	APPROVED <i>River</i>	DATE 02/04/15'		
SHEET 1 OF 1					