

PROPRIETARY INFORMATION
COMPANY CONFIDENTIAL

REV.	ECN. NO.	DESCRIPTION	ENG	DATE
A		INITIAL	Knight	02/02/15'
B		UPDATE DIMENSION	Knight	05/31/16'

NOTES:

- CURRENT RATING: 1.5A
- CONTACT RESISTANCE: 30mΩ MAX
- INSULATION RESISTANCE: 1000MΩ MIN
- DIELECTRIC WITHSTANDING VOLTAGE: 500V AC MAX
- INSERTION FORCE: 3.5(kg)MAX.
- EXTRACTION FORCE: 1.0(kg)MIN.
- RoHS COMPLIANCE

ORDER INFORMATION

USAR-6W 08 - A K 1 3 T
① ② ③④⑤⑥⑦

- TYPE:
USAR-6W:USB DUAL PORT A TYPE
- POSITIONS:
08:08 POSITIONS
- INSULATOR MATERIAL:
A: PBT
- INSULATOR COLOR:
K: BLACK
- CONTACT PLATING:
1: GOLD FLASH
- SHIELD PLATING:
3: NICKEL PLATING
- PACKING
T: TRAY

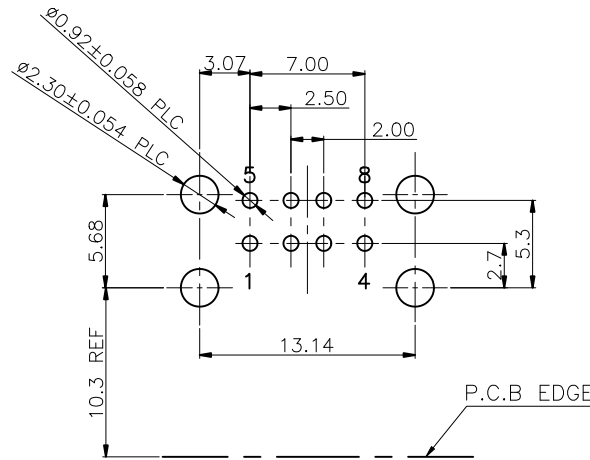
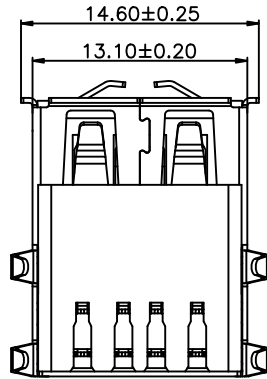
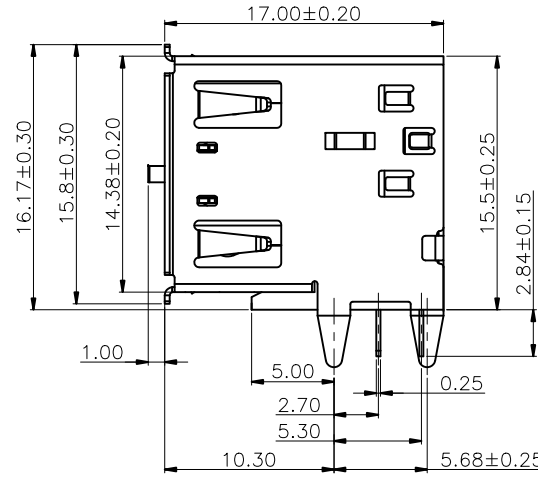
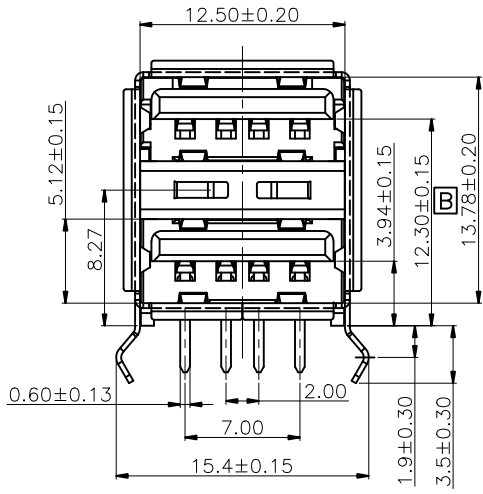

RECOMMENDED P.C.B LAYOUT COMPONENT SIDE
P.C.B THICKNESS=1.60mm TOLERANCE=±0.05

ITEM	NAME	Q'TY	DESCRIPTION	NOTE
4	REAR COVER	1	SPCC, NICKEL 80u" MIN PLATING OVERALL	
3	SHELL	1	SPCC, NICKEL 80u" MIN PLATING OVERALL	
2	CONTACT	4	BRASS, GOLD FLASH PLATING ON CONTACT AREA, TIN 100u" MIN PLATING SOLDER AREA, NICKEL 50u" MIN UNDER PLATING OVERALL	
1	HOUSING	1	PBT+30%G.F	BLACK, UL94 V-0

GENERAL TOLERANCE X±0.50 .X±0.38 .XX±0.25 .XXX±0.15	ANGLE TOLERANCE X°±5.0° .X°±3.0° .XX°±2.0° .XXX°±1.0°	DRAWN <i>Knight</i>	DATE 05/31/16'
MATERIAL SEE BOM		CHECKED	DATE
FINISH SEE NOTES		APPROVED <i>River</i>	DATE 05/31/16'
SCALE N/A	UNIT mm		
SHEET 1 OF 1			

		TITLE USB DUAL PORT A TYPE	
		PART NUMBER USAR-6W08-AK13T	
DRAWING NO. GT26-210399		SIZE A4	REV. B