

PROPRIETARY INFORMATION  
COMPANY CONFIDENTIAL

REV.	ECN. NO.	DESCRIPTION	ENG	DATE
X1		INITIAL	Hill	3/18/15"

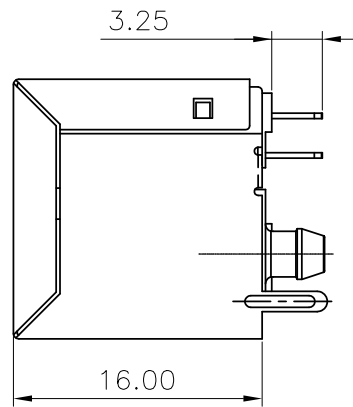
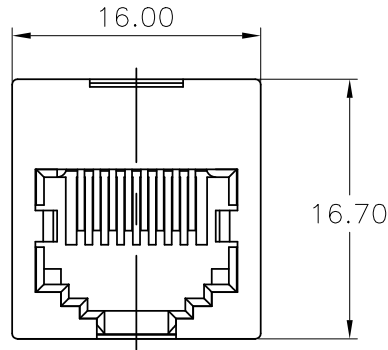

Notes:

- Materials:
  - Housing: Black Glass Filled Thermoplastic(UL94V-0)
  - RJ contacts: Phosphor Bronze  
Finish: Selective gold plate see table
  - Shield Material: Copper Alloy
- Tolerances comply with EIA/TIA 568 dimension requirements
- Wave solder compatible for 260°C for 5 seconds
- UL approval Per DUXR2 & DUXR8

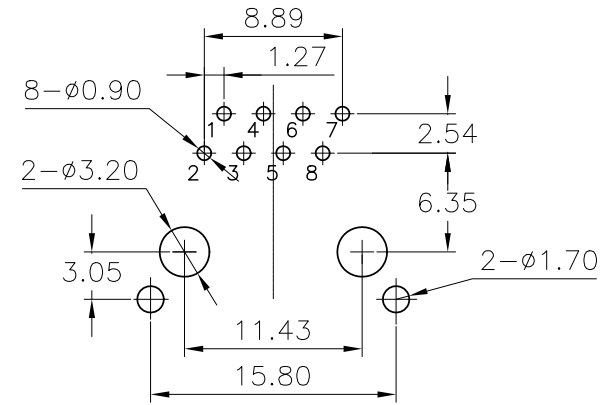

PC Board Layout t=1.6mm  
Component Side Show



MP45-W01E-60V-00W5	50 Micro Inches
MP45-W01E-60V-00W4	30 Micro Inches
MP45-W01E-60V-00W3	15 Micro Inches
MP45-W01E-60V-00W2	6 Micro Inches
MP45-W01E-60V-00W1	Flash
Part Number	RJ Contact Plating Thickness (Au)

GENERAL TOLERANCE	ANGLE TOLERANCE	DRAWN	DATE	
X± 0.50 .X± 0.38 .XX± 0.25 .XXX± 0.15	X°± 5.0° .X°± 3.0° .XX°± 2.0° .XXX°± 1.0°	Ryan	3/19/15"	
MATL <i>SEE BOM</i>	FINISH <i>SEE BOM</i>	CHECKED Hill	DATE 3/19/15"	PART NUMBER: MP45-W01E-60V-00WX
SCALE <i>N/A</i>	UNIT <i>mm</i>	APPROVED Bryan	DATE 3/19/15"	DRAWING NO. GT26-700328
SHEET 1 OF 1				SIZE <i>A4</i> REV. <i>X1</i>